



## VWR™ Critical Cover® Shoe & Boot Covers

**Providing**  
**Protection &**  
**Comfort**  
**AquaTrak®**



Clockwise from upper left:  
33100-032, 14001-028, 14001-076, 47735-718

## AquaTrak® Shoe & Boot Covers

AquaTrak® shoe and boot covers are the ultimate solution for wet or dry conditions. The combination of fluid barrier, traction and durability cannot be matched. In addition, all styles of the AquaTrak line are fluid impervious in material and construction with the exception of the serged seam ankle high boot covers.



## Shoe Covers

### Heat Sealed

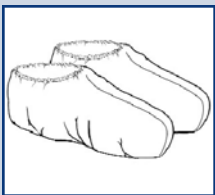

Heat sealed, impervious,  
75pair/case

33100-040	Univ	Blue
33100-032	XL	Blue
33100-038	Univ	White
33100-030	XL	White
33100-036	Univ	Black
33100-034	XL	Black

Fluid impervious. Elastic seam along sole provides added traction and snug fit. Elastic cuff.

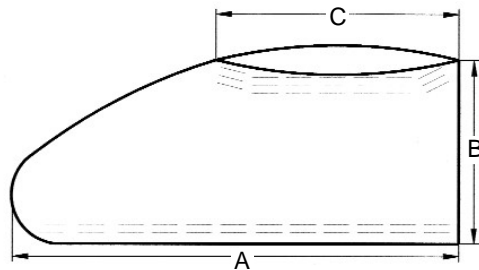

### Dimensions - Shoe Covers

Size	Univ	XL
Length (A)	15.00"	17.00"
Height (B)	7.50"	7.50"
Top (Relaxed) (C)	5.00"	6.00"
Top (Stretched) (C)	10.00"	12.00"

<b>Physical Properties Testing</b>		
<b>Standard Applied</b>	<b>Test Method</b>	<b>Results</b>
<b>COF</b> (Coefficient of Friction)	ASTM D1894 Static Kinetic	0.619 0.607
<b>Water Resistance Impact Penetration</b>	AATCC Method 42	No Visible Penetration
<b>Hydrostatic Resistance</b>	ASTM D751-95	Mean 20 psi
<b>BFE</b> (Bacterial Filtration Efficiency)	MIL-M-36954C	99.9%
<b>Helmke Drum (unwashed)</b>	IEST-RP-CC003.2 (Modified)	Particles / cubic ft. @ 0.5 microns 62
<b>Grab Tensile Properties</b>	ASTM D751 MD-Tensile Strength* TD-Tensile Strength*	Mean 27.5 lb. 39.5 lb.
<b>Mass/Unit Area</b>	ASTM D751	Mean 1.75 oz/sq. yd.
<b>Mullen Burst Strength</b>	ASTM D 3786, Modified	Mean 146 psi
<b>Ball Burst Strength</b>	ASTM D 3787 Puncture Strength	Mean 22.7 lb.
<b>Trapezoid Tearing Strength</b>	ASTM D 4533 MD-Tear Strength* TD-Tear Strength*	Mean 12.2 lb. 17.4 lb.
<b>Water Vapor Transmission</b>	ASTM E 96	Mean 0.57 g/m <sup>2</sup> /hr
<b>Puncture Propagation Tear Resistance</b>	ASTM D2582 MD-Tear Resistance* TD-Tear Resistance*	Mean 9.9 lb. 8.6 lb.

\*MD - Machine Direction

TD - Transverse Direction

These garments and associated materials are not suitable for use in some environments containing some chemicals, hazardous agents, and risk of flame and fire. These materials can generate static electricity. It is the user's responsibility to determine the level of risk in a particular environment and the proper personal protective equipment needed. Because conditions or use are out of Alpha Pro Tech's control, Alpha Pro Tech makes no warranties, expressed or implied, and assumes no liability as to the performance of these products for a particular use.

## Ankle High Boot Covers

### Sonic Welded Seamless Bottom

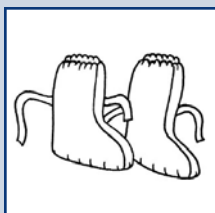

Sonic welded seams, tunneled elastic top, ankle ties  
100pair/case

14001-072	S	Blue
14001-074	M	Blue
14001-076	Univ	Blue
14001-078	XL	Blue

Fluid impervious material and construction. Ankle ties provide snug fit and security. Seamless sole provides comfort and traction. Tunneled elastic top ensures good closure and support.

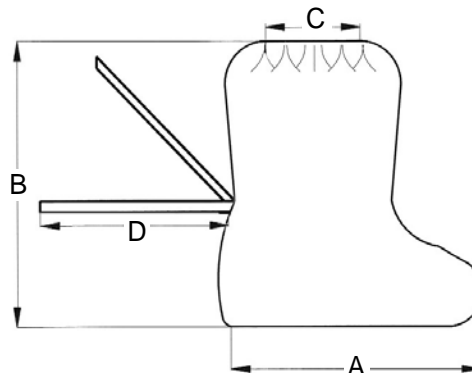

Dimensions - Boot Covers				
Size	S	M	Univ	XL
Length (A)	12.75"	13.25"	15.50"	16.00"
Height (B)	14.75"	16.25"	17.00"	18.00"
Top (Relaxed) (C)	5.50"	5.75"	6.00"	6.50"
Top (Stretched) (C)	9.75"	10.50"	11.50"	12.50"
Tie Length (D)	16.00"	16.00"	17.50"	17.50"

### Serged Seams



Elastic all around, serged seams  
100pair/case

47735-722	Univ	White
47735-720	XL	Blue
47735-718	2X	Black

Ideal for dry conditions, as well as light surface wetness. Elastic seams provide secure closure and snug fit. Color coded by size for easy identification.

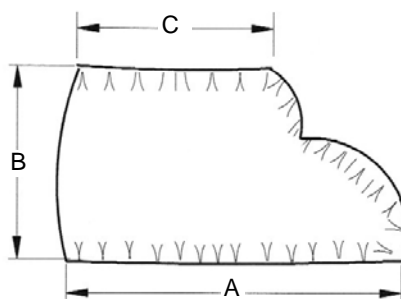

Dimensions - Boot Covers			
Size	Univ	XL	2X
Length (A)	16.00"	17.50"	19.50"
Height (B)	12.00"	12.00"	12.50"
Top (Relaxed) (C)	5.00"	5.25"	5.50"
Top (Stretched) (C)	10.50"	11.00"	12.00"

## High Top Boot Covers

### Sonic Welded Seamless Bottom

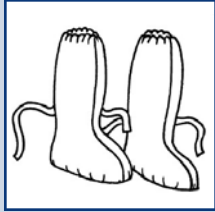

Sonic welded seams, tunneled elastic top, ankle ties  
100pair/case

14001-024	S	Blue
14001-026	M	Blue
14001-028	Univ	Blue
14001-030	XL	Blue

Fluid impervious material and construction. Seamless sole provides comfort and traction. Ankle ties provide snug fit and security. Tunneled elastic top ensures good closure and support.

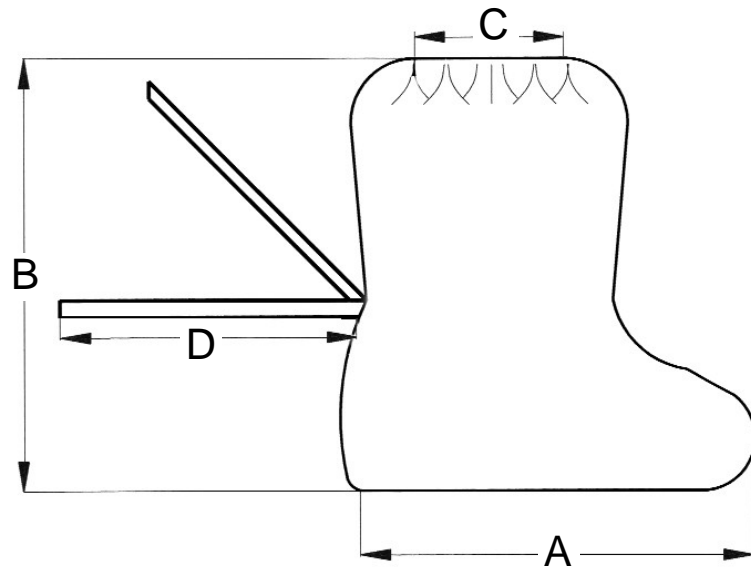

Dimensions - Boot Covers				
Size	S	M	Univ.	XL
Length (A)	13.00"	14.00"	15.00"	16.50"
Height (B)	21.00"	22.00"	23.00"	24.00"
Top (Relaxed) (C)	5.00"	5.25"	5.75"	6.00"
Top (Stretched) (C)	10.00"	11.00"	11.75"	13.50"
Tie Length (D)	17.00"	17.00"	17.00"	17.00"

# Design Excellence in Seam Construction

## Heat Sealed Seams

When ultrasonics are not compatible with the materials in use, heat sealing will deliver equally strong and impervious results.

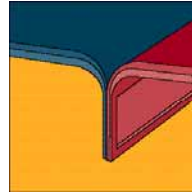

## Sonically Welded Seams

When the materials are compatible with ultrasonics, the strength and barrier properties achieved with this seam option are exceptional.

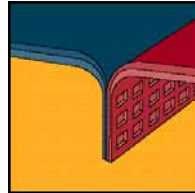

## Serged Seams

These are the most common seams and provide a balance of strength, fluid and particulate control. They are formed with overlapping stitches with high stitch count for performance.

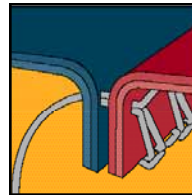

## Tunneled Elastic

These seams are used to provide secure closure and garment stability in addition to particulate and fluid control at garment openings.

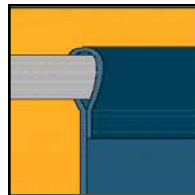

---

---

## Packaging Perfection



### General Use Packaging Standard

- All products are packaged in a poly bag as primary packaging, and a corrugated box as secondary packaging, (tertiary optional).
- Two corner labels allow product identification from all sides.



**VWR.com**  
1.800.932.5000

## Order from Over 750,000 Products

### Sales & Inventory Locations

#### Pacific

#### Northwest

Anchorage, AK  
Boise, ID  
Brisbane, CA  
Seattle, WA  
Tualatin, OR

#### Southwest

Albuquerque, NM  
Aurora, CO  
Phoenix, AZ  
San Diego, CA  
San Dimas, CA

#### Midwest

Batavia, IL  
Indianapolis, IN  
Minneapolis, MN  
St. Louis, MO

#### Gulf

Houston, TX  
Lake Charles, LA  
Sugarland, TX

#### Northeast

Marlborough, MA  
Rochester, NY

#### Mid-Atlantic

Bridgeport, NJ  
Clarksburg, MD

#### Southeast

Morrisville, NC  
Suwanee, GA

#### Canada

Mississauga, Ontario  
Ville Mont-Royal,  
Québec

### Call Direct for Specialized Service Locations

#### International

911 Commerce Ct.  
Buffalo Grove, IL 60089  
847-520-6170  
fax: 847-229-0788

#### Puerto Rico

Carr. #869, Km. 1.5 M-4  
Royal Industrial Park  
Catano, PR 00962  
800-932-5000  
787-275-4500  
fax: 787-788-4320

#### Global and Corporate Accounts

1310 Goshen Pkwy.  
West Chester, PA 19380  
610-431-1700  
fax: 610-431-9174

#### Mexico

Super Av. Lomas Verdes  
No. 464 2o Piso Col.  
Los Alamos C.P. 53230  
Naucalpan de Juarez,  
Edo, de Mexico 2122-1600  
011-52-552-122-1630  
fax: 011-52-555-344-7532

#### Production Supplies and Services

975 Overland Ct.  
San Dimas, CA 91773  
877-VWR-PSCS  
(877-897-7727)  
fax: 888-890-9124

#### Furniture Group

3021 Gateway Drive  
Suite 280  
Irving, TX 75063  
888-624-2432  
fax: 972-753-1389

#### VWR Laboratory Distributors Services

911 Commerce Ct.  
Buffalo Grove, IL 60089  
800-873-8971  
fax: 847-229-0668

VWR Products:  
Providing value at competitive prices

